

CUSTOMER PRINT

PART NUMBER: 3382-XSG-5XXW(CCX)

NOTES:

1. ALL PART TO BE BULK PACKED.
2. CONTACT ASSEMBLED INTO CONNECTOR AS SHOWN.
3. ALL DIMENSIONS ARE REFERENCE EXCEPT WHERE NOTED WITH TOLERANCE.

ASS'Y P/N	COUPLING RING COLOR
3282-XSG-5XXWCC1	WHITE
3282-XSG-5XXWCC2	RED
3282-XSG-5XXWCC3	BLUE
3282-XSG-5XXWCC4	LIGHT GREY
3282-XSG-5XXWCC5	YELLOW
3282-XSG-5XXWCC6	MAROON
3282-XSG-5XXWCC7	GREEN

KIT P/N	NO. OF CONTACTS
3382-4SG-5XXW	(4) - #16
3382-5SG-5XXW	(5) - #16
3382-6SG-5XXW	(6) - #16

GROMMET SIZE SEE TABLE

CONN. KIT P/N	GROMMET FOR CABLE	"X" DIM.
3382-XSG-515W	.156 I.D. FOR CABLE .15-.17 O.D. [3.8-4.3mm]	Ø0.77 [19.6mm]
3382-XSG-518W	.187 I.D. FOR CABLE .18-.20 O.D. [4.6-5.1mm]	Ø0.77 [19.6mm]
3382-XSG-521W	.225 I.D. FOR CABLE .21-.23 O.D. [5.3-5.8mm]	Ø0.77 [19.6mm]
3382-XSG-524W	.250 I.D. FOR CABLE .24-.27 O.D. [6.1-6.8mm]	Ø0.77 [19.6mm]
3382-XSG-528W	.285 I.D. FOR CABLE .28-.29 O.D. [7.1-7.4mm]	Ø0.77 [19.6mm]
3382-XSG-530W	.312 I.D. FOR CABLE .30-.32 O.D. [7.6-8.1mm]	Ø0.77 [19.6mm]
3382-XSG-535W	.375 I.D. FOR CABLE .35-.40 O.D. [8.9-10.2mm]	Ø0.83 [21.1mm]

NO. OF CONTACTS

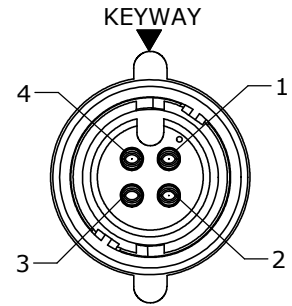

FACE VIEW

ASSY: 3382-4SG-5XXW

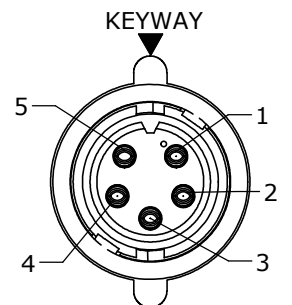

FACE VIEW

ASSY: 3382-5SG-5XXW

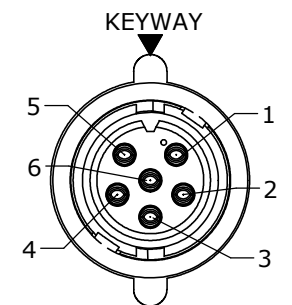

FACE VIEW

ASSY: 3382-6SG-5XXW

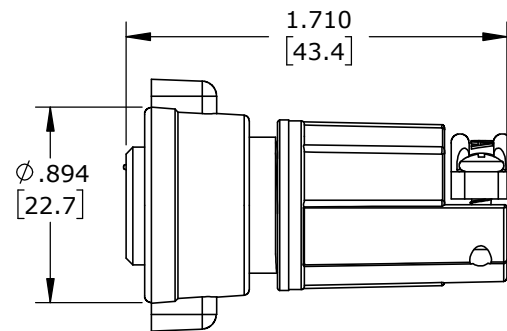
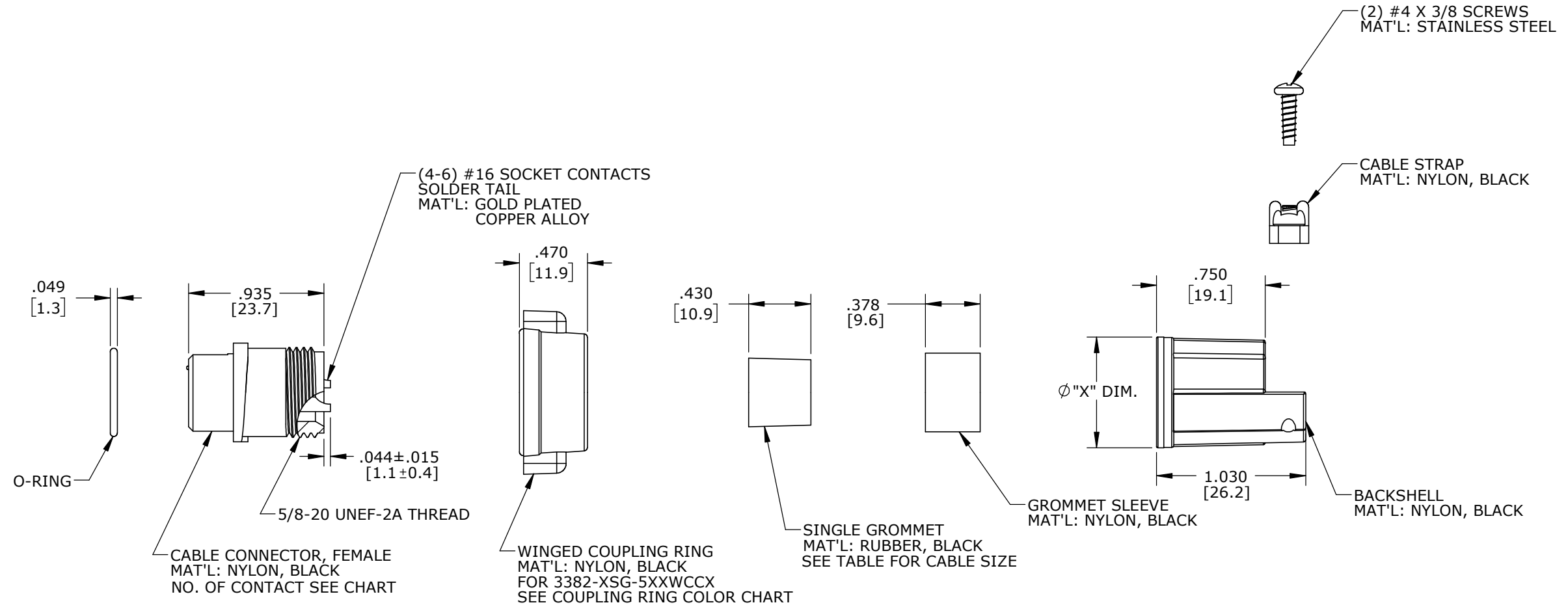

SHOWN ASSEMBLED KIT
FOR CUSTOMER REFERENCE ONLY

CUSTOMER APPROVAL

THIS DOCUMENT CONTAINS CONFIDENTIAL INFORMATION PROPRIETARY TO CONXALL CORPORATION. ANY REPRODUCTION, DISCLOSURE, OR USE OF THIS DOCUMENT /INFORMATION IS EXPRESSLY PROHIBITED UNLESS AUTHORIZED IN WRITING BY CONXALL CORPORATION.

APPROVED BY: _____

DATE: _____

DIMENSIONS IN BRACKETS [] ARE METRIC

RoHS COMPLIANT

REV.	INIT.	DATE	DESCRIPTION
A	AN	02-24-21	DRAWING CREATED PER 15-E253SL#39
<small>ALL INFORMATION ILLUSTRATED IS THE PROPERTY OF CONXALL CORPORATION. UNAUTHORIZED DUPLICATION OR DISTRIBUTION OF THIS DOCUMENT IS PROHIBITED.</small>			<small>ORIG. DRAWN BY: AN</small> <small>DATE: 02-24-21</small>
<small>ALL UNITS ARE IN FEET, INCHES, FRACTION OF INCHES AND DECIMALS.</small>			
<small>601 E. WILDWOOD VILLA PARK, IL 60181</small>			TITLE: CABLE CONNECTOR KIT (4-6) #16 SOCKET CONTACTS, SOLDER MULTI-CON-X CUSTOMER: STANDARD PRODUCT
SCALE	SIZE	SHEET	
NTS	B	1 OF 1	
FILE:	DIRECTORY:	PART NUMBER:	REV
3382-XSG-5XXW(CCX)	SLW	3382-XSG-5XXW(CCX)	A