

ASS'Y P/N	CONTACT QTY.
4280-4SG-300	4 #20
4280-5SG-300	5 #20
4280-6SG-300	6 #20
4280-7SG-300	7 #20
4280-8SG-300	8 #20
4280-9SG-300	9 #20

- NOTES:**
1. ALL PARTS TO BE BULK PACKED.
 2. SEE DRAWING HPMUSTD FOR HOLE PATTERN.
 3. ALL DIMENSIONS ARE REFERENCE EXCEPT THOSE WITH A TOLERANCE

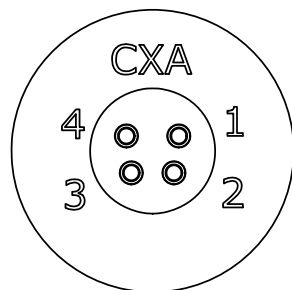

WIRING VIEW
ASSY: 4280-4SG-300

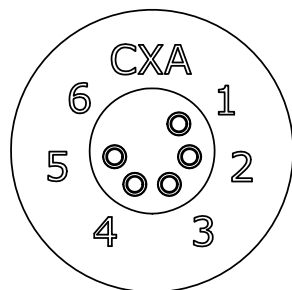

WIRING VIEW
ASSY: 4280-5SG-300

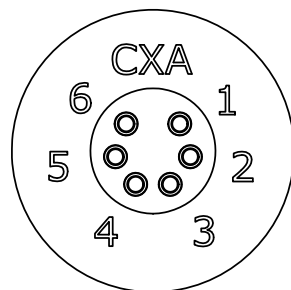

WIRING VIEW
ASSY: 4280-6SG-300

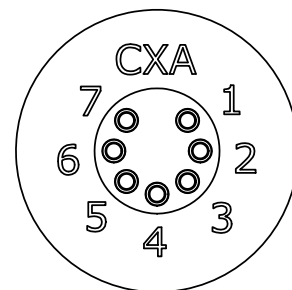

WIRING VIEW
ASSY: 4280-7SG-300

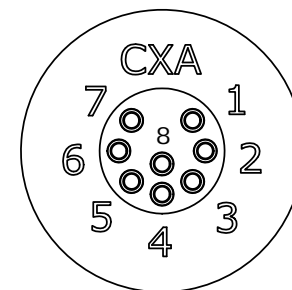

WIRING VIEW
ASSY: 4280-8SG-300

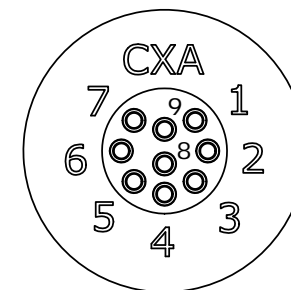

WIRING VIEW
ASSY: 4280-9SG-300

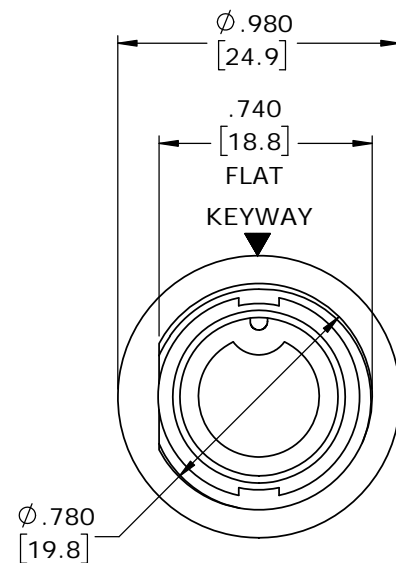

FACE VIEW

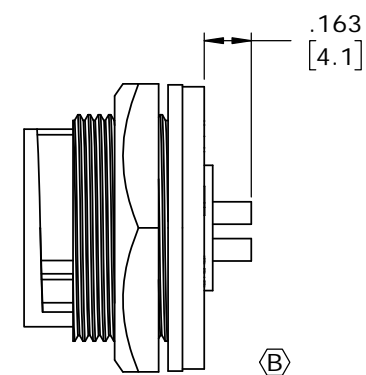
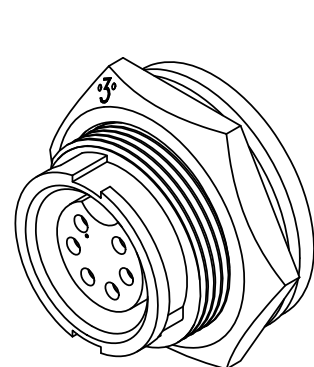
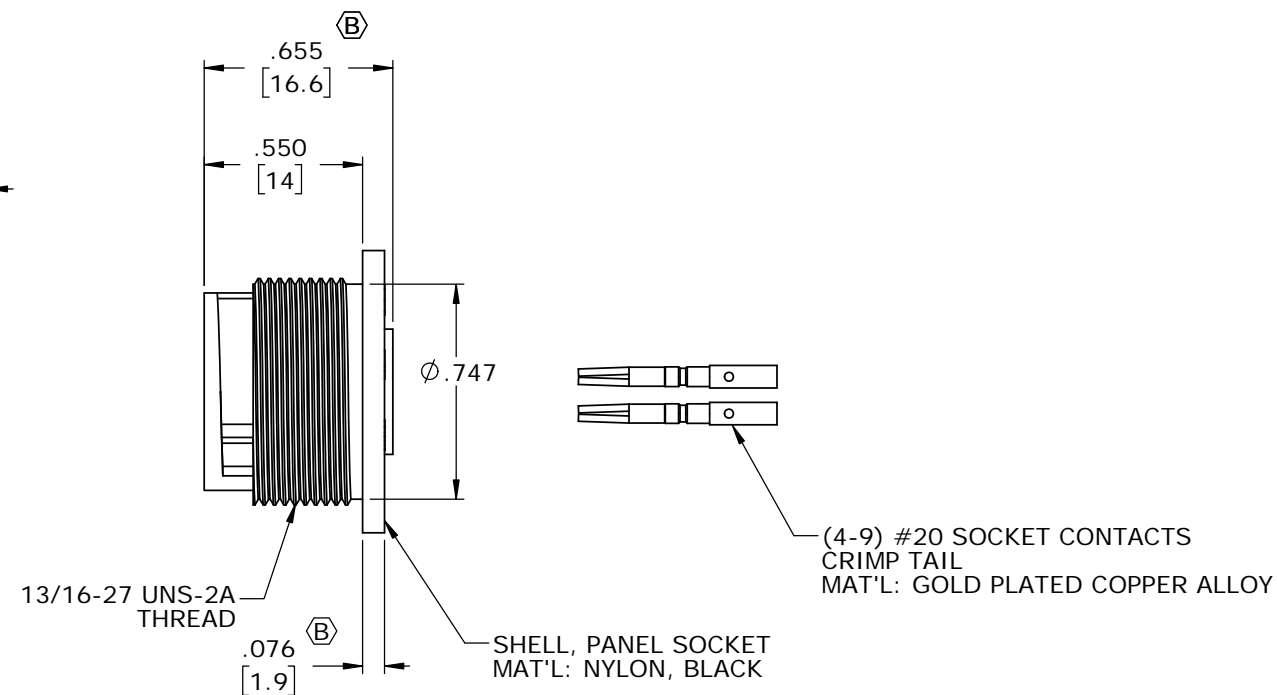
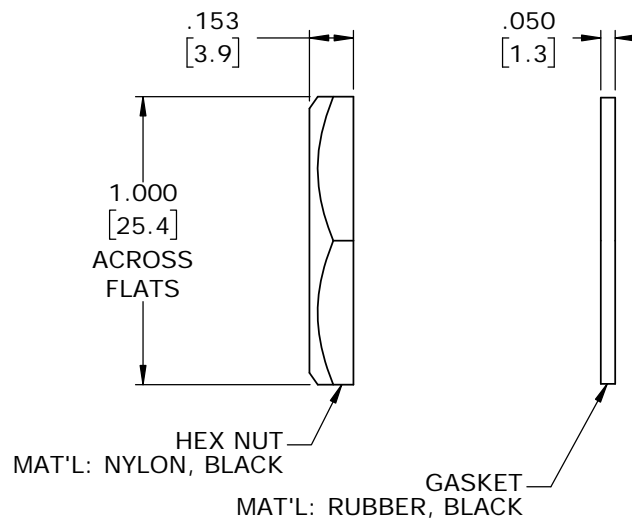

CONTACT HEIGHT

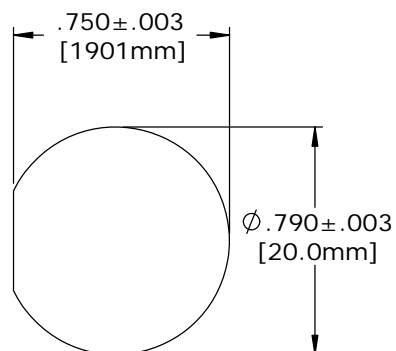

RECOMMENDED PANEL CUT OUT

CUSTOMER APPROVAL

THIS DOCUMENT CONTAINS CONFIDENTIAL INFORMATION PROPRIETARY TO CONXALL CORPORATION. ANY REPRODUCTION, DISCLOSURE, OR USE OF THIS DOCUMENT /INFORMATION IS EXPRESSLY PROHIBITED UNLESS AUTHORIZED IN WRITING BY CONXALL CORPORATION.

APPROVED BY: _____
DATE: _____

B	MA	12-03-18	INSERT OVERALL DIM WAS .663 or .656. FLANGE THICKNESS WAS .075. ADDED CONTACT HEIGHT VIEW PER ECR 9369
A	AN	03-15-11	DRAWING CREATED PER DOR 11-E149SL SUPERSEDED DWG. 4280-4SG-300 & 4280-9SG-300
REV.	INIT.	DATE	DESCRIPTION
AN		03-04-11	
ALL INFORMATION ILLUSTRATED IS THE PROPERTY OF "CONXALL CORPORATION". UNAUTHORIZED DUPLICATION OR DISTRIBUTION OF THIS DOCUMENT IS PROHIBITED.			<p>601 E. WILDWOOD VILLA PARK, IL 60181</p>
ALL UNITS ARE IN FEET, INCHES, FRACTION OF INCHES AND DECIMALS.			
APPROVED BY:		TITLE: PANEL MOUNT ASSEMBLY (4-9) #20 SOCKET CONTACTS MULTI-CON-X	
SCALE: NTS		CUSTOMER: STANDARD PRODUCT	
FILE: 4280-XSG-300	DIRECTORY: SLW	PART NUMBER: 4280-XSG-300	REV B

RoHS COMPLIANT

DIMENSIONS IN BRACKETS [] ARE IN MILLIMETERS

CUSTOMER PRINT

PART NUMBER: 4280-XSG-300