

CUSTOMER PRINT

PART NUMBER: 4282-XPG-300FAM

ASSY P/N	NO. OF CONTACTS
4282-4PG-300	4
4282-5PG-300	5
4282-6PG-300	6
4282-7PG-300	7
4282-8PG-300	8
4282-9PG-300	9

- NOTES:  
 1. PARTS TO BE BULK PACKED  
 2. CONTACTS TO BE INSERTED INTO PANEL CONNECTOR

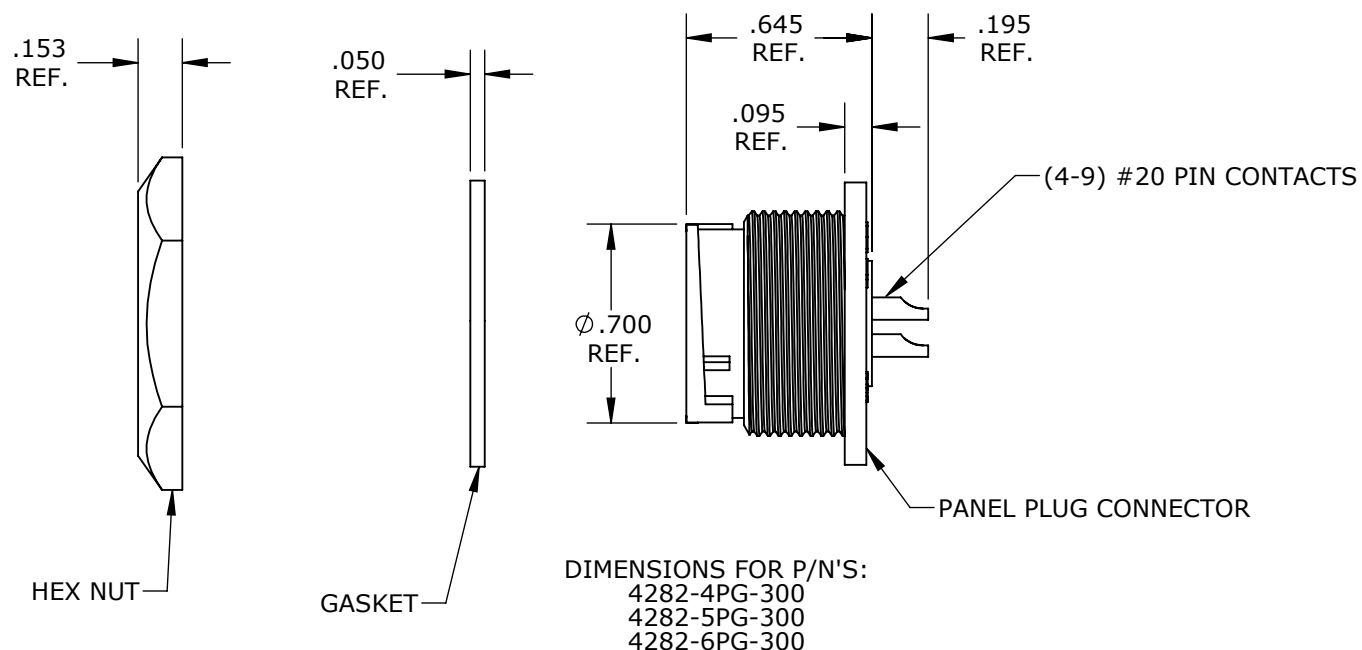

DIMENSIONS FOR P/N'S:  
 4282-4PG-300  
 4282-5PG-300  
 4282-6PG-300

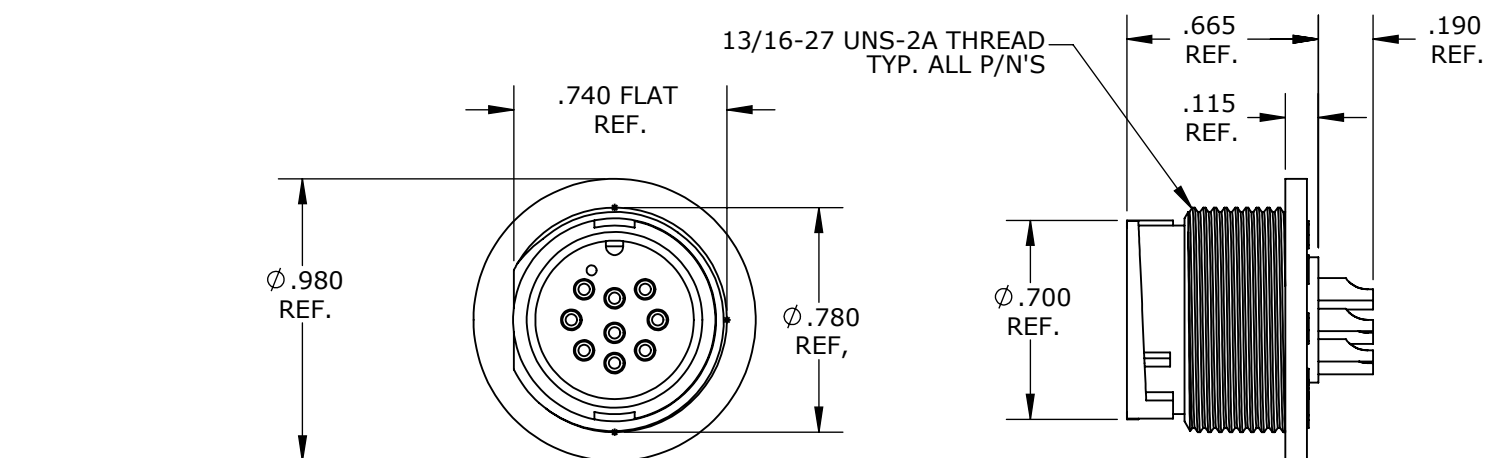

**MATING FACE**  
 DIMENSION TYP.  
 ALL PART NO.S

DIMENSIONS FOR P/N'S:  
 4282-7PG-300  
 4282-8PG-300  
 4282-9PG-300

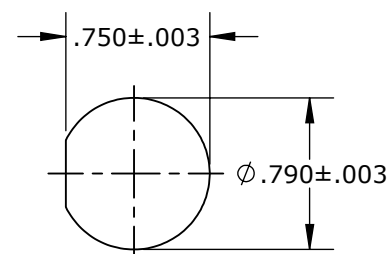

**RECOMMENDED  
 PANEL CUTOUT**

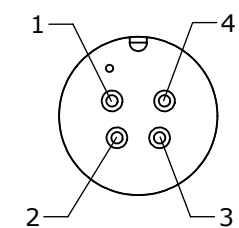

**MATING FACE**  
 4282-4PG-300

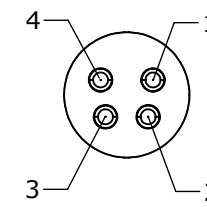

**WIRING VIEW**  
 4282-4PG-300

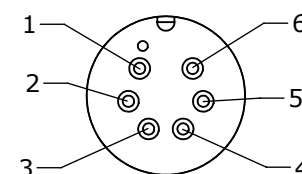

**MATING FACE**  
 4282-6PG-300

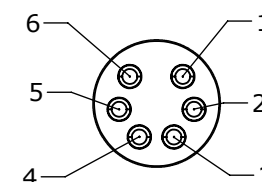

**WIRING VIEW**  
 4282-6PG-300

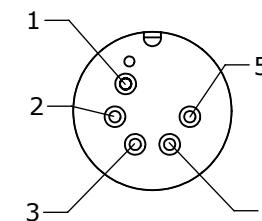

**MATING FACE**  
 4282-5PG-300

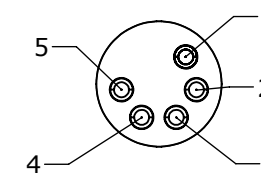

**WIRING VIEW**  
 4282-5PG-300

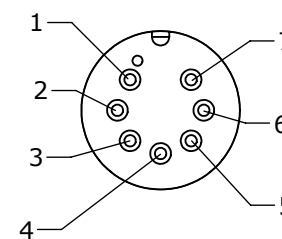

**MATING FACE**  
 4282-7PG-300

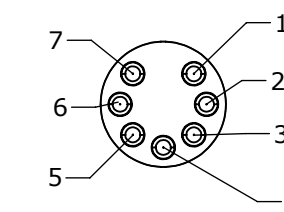

**WIRING VIEW**  
 4282-7PG-300

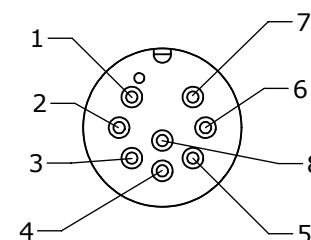

**MATING FACE**  
 4282-8PG-300

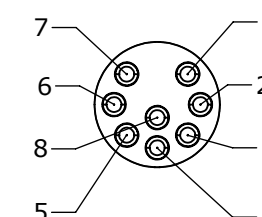

**WIRING VIEW**  
 4282-8PG-300

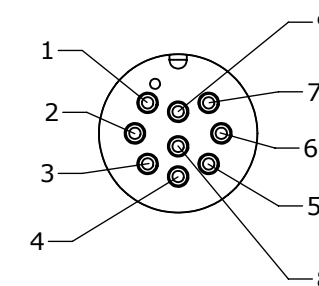

**MATING FACE**  
 4282-9PG-300

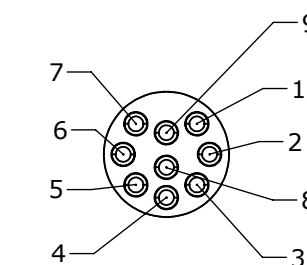

**WIRING VIEW**  
 4282-9PG-300

**CUSTOMER APPROVAL**

THIS DOCUMENT CONTAINS CONFIDENTIAL INFORMATION PROPRIETARY TO CONXALL CORPORATION. ANY REPRODUCTION, DISCLOSURE, OR USE OF THIS DOCUMENT / INFORMATION IS EXPRESSLY PROHIBITED UNLESS AUTHORIZED IN WRITING BY CONXALL CORPORATION.

APPROVED BY: \_\_\_\_\_  
 DATE: \_\_\_\_\_

REV.	INIT.	DATE	DESCRIPTION
A	BZ	03-04-09	UPDATED DIMENSIONS TO MATCH FINIAL PRODUCT
		02-26-09	DRAWING CREATED PER DOR 09-E149SL
ALL INFORMATION ILLUSTRATED IS THE PROPERTY OF "CONXALL CORPORATION". UNAUTHORIZED DUPLICATION OR DISTRIBUTION OF THIS DOCUMENT IS PROHIBITED.			<p>601 E. WILDWOOD VILLA PARK, IL 60181</p>
ALL UNITS ARE IN FEET, INCHES, FRACTION OF INCHES AND DECIMALS. UNLESS OTHERWISE SPECIFIED TOLERANCES: 3 PLACE DECIMALS ±.005 ANGLES ±1° FRACTIONS ±1/16			
FILE: 4282-XPG-300FAM			TITLE: PANEL PLUG ASSEMBLY (4-9) #20 PIN CONTACTS MULTI-CON-X CUSTOMER: STANDARD PRODUCT PART NUMBER: 4282-XPG-300FAM
SCALE: NTS SIZE: B SHEET: 1 OF 1			REV: A