

Ø0.138 THRU  
 ✓ Ø0.230 X 82°  
 (2) PLACES  
 REF

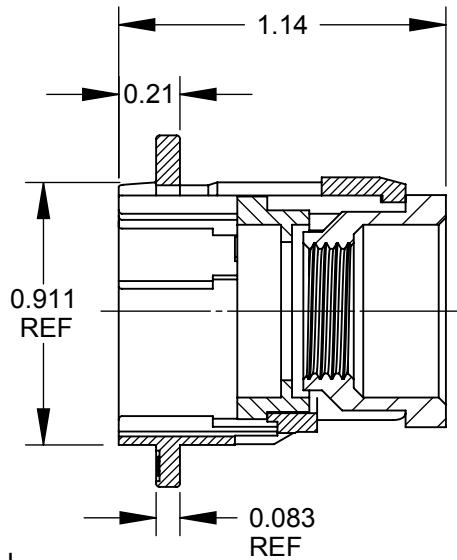

**SECTION A-A**

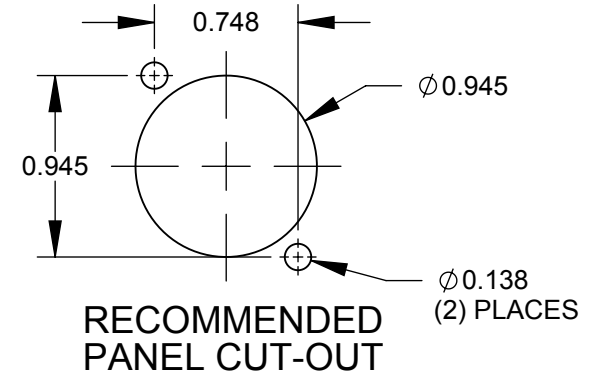
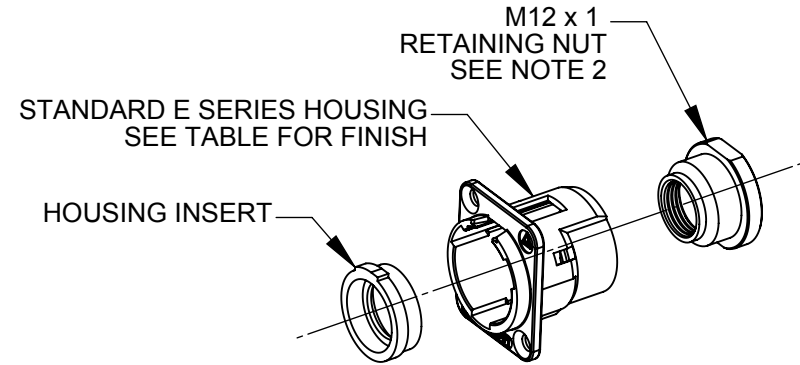

**NOTES:**

1. USED WITH BPJJ SERIES BULKHEAD RCA JACKS. SAME AS EHRCA2X WITHOUT JACKS.
2. MAX TORQUE: 240 OZ-IN.
3. ADD "PKG" SUFFIX TO INCLUDE MOUNTING SCREWS AND INDIVIDUAL PACKAGING.
4. MATERIALS:  
 HOUSING - ZINC ALLOY  
 HOUSING INSERT - THERMOPLASTIC, BLACK  
 RETAINING NUT - THERMOPLASTIC, BLACK
5. THIS PRODUCT IS RoHS COMPLIANT.

PART NUMBER	HOUSING FINISH
EH1	NICKEL
EHB1	BLACK CHROME

**CUSTOMER DRAWING**

					THIS DRAWING DESCRIBES A DESIGN CONSIDERED PROPRIETARY IN NATURE, DEVELOPED AND MANUFACTURED BY SWITCHCRAFT INC. AND IS RELEASED ON A CONFIDENTIAL BASIS FOR IDENTIFICATION PURPOSES ONLY.								
UNLESS OTHERWISE SPECIFIED  1. ALL DIMENSIONS IN INCHES - TWO PLACE DECIMALS ±0.02 - THREE PLACE DECIMALS ±0.005					SIZE	WIDTH	MULT	LBS/M	TEMPER				
					FINISH				MATERIAL				
					SPEC No.				SPEC No.				
					FIRST USED ON				SCALE 1.5:1				
A	26411	7/10/09	RS	TJK	DATE DRAWN	BY	CHKD	APVD					
REV	ECO NUMBER	DATE	BY	APVD	6/25/09	RS	RS	TJK					
REVISIONS					DO NOT SCALE DRAWING								
					NAME E SERIES CONNECTOR RCA FEEDTHROUGH KIT w/o JACK, RoHS				PART No. EH1-EHB1				
									REV A				

