

MFG. ENG.	APPROVED BY:	DATE:	APPROVED BY:	DATE:
			QA	

**NOTES:**

1. ALL PARTS ARE BULK PACKED.
2. REFER TO DRAWING HPMCSTD FOR CONTACT PATTERNS.
3. SOLDER CUPS ARE TO BE FACING TOP KEY DIRECTION.
4. ALL DIMENSIONS ARE REFERENCE ONLY IN INCHES [mm], WITHIN ±0.015 UNLESS OTHERWISE NOTED.

ASS'Y P/N	CONTACT QTY.	CABLE O.D. RANGE
W18282-2PG-P-518	2	0.18 - 0.20 [4.6 - 5.1]
W18282-2PG-P-521	2	0.21 - 0.22 [5.3 - 5.6]
W18282-2PG-P-522	2	0.22 - 0.23 [5.6 - 5.8]
W18282-3PG-P-518	3	0.18 - 0.20 [4.6 - 5.1]
W18282-3PG-P-521	3	0.21 - 0.22 [5.3 - 5.6]
W18282-3PG-P-522	3	0.22 - 0.23 [5.6 - 5.8]
W18282-XPG-P-5XX		

# OF CONTACTS

GROMMET SIZE = CABLE O.D. RANGE:

- 518 = 0.18 - 0.20 [4.6 - 5.1]
- 521 = 0.21 - 0.22 [5.3 - 5.6]
- 522 = 0.22 - 0.23 [5.6 - 5.8]

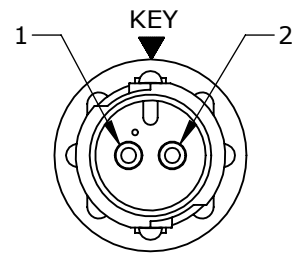

**FACE VIEW**  
W18282-2PG-P-5XX

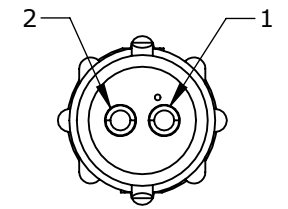
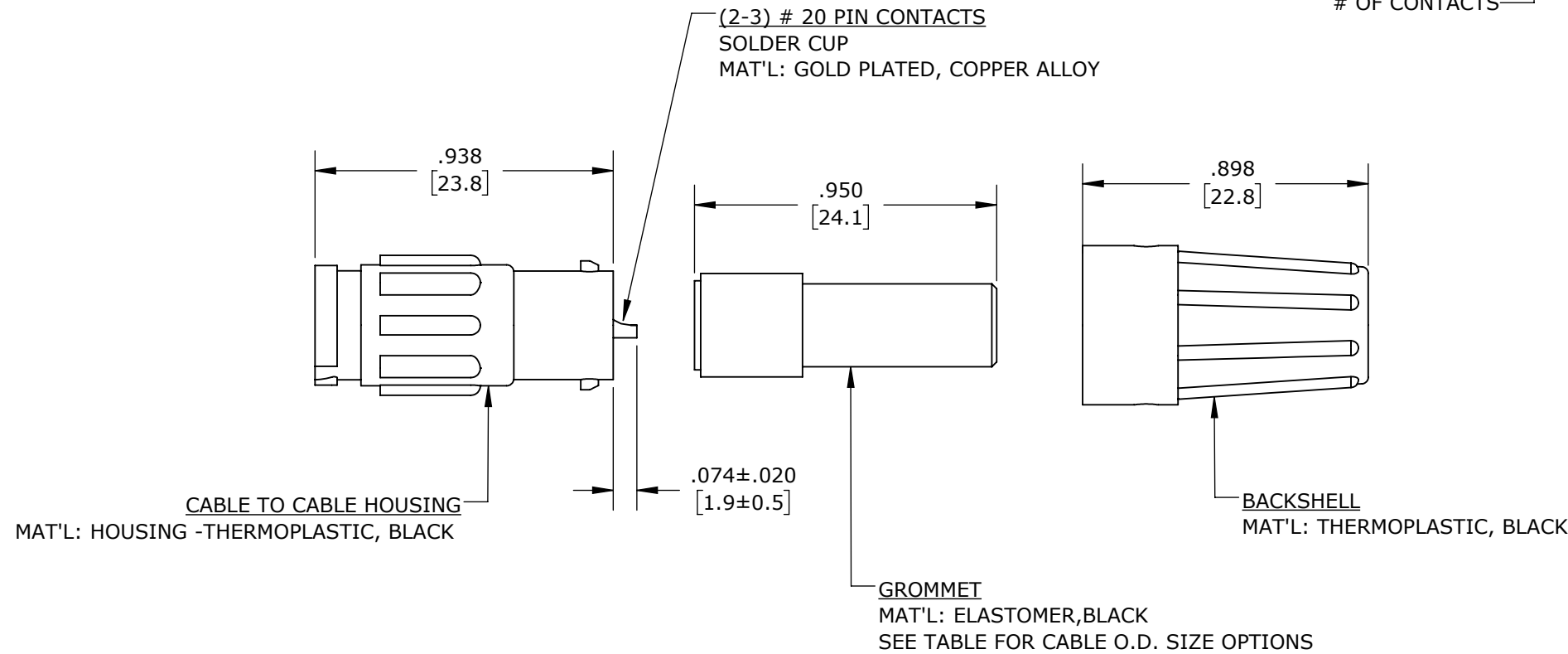

**WIRING VIEW**  
W18282-2PG-P-5XX

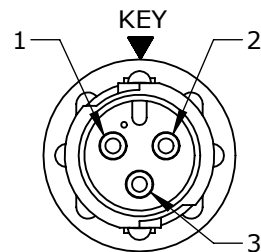

**FACE VIEW**  
W18282-3PG-P-5XX

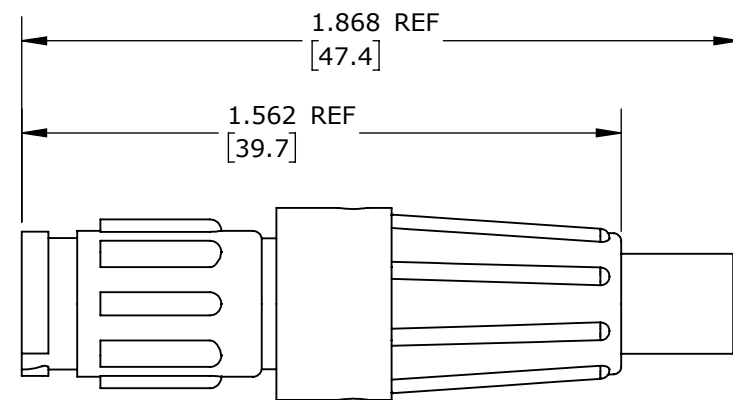

**ASSEMBLED VIEW**  
FOR CUSTOMER REF. ONLY

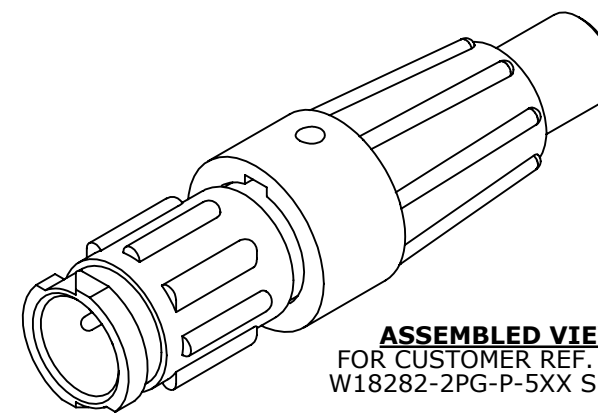

**ASSEMBLED VIEW**  
FOR CUSTOMER REF. ONLY  
W18282-2PG-P-5XX SHOWN

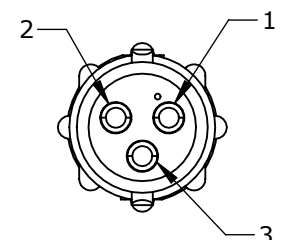

**WIRING VIEW**  
W18282-3PG-P-5XX

CUSTOMER PRINT

PART NUMBER: W18282-XPG-P-5XX

**PRELIMINARY**

DIMENSIONS IS BRACKETS [ ] ARE METRIC

**CUSTOMER APPROVAL**

THIS DOCUMENT CONTAINS CONFIDENTIAL INFORMATION PROPRIETARY TO CONXALL CORPORATION. ANY REPRODUCTION, DISCLOSURE, OR USE OF THIS DOCUMENT /INFORMATION IS EXPRESSLY PROHIBITED UNLESS AUTHORIZED IN WRITING BY CONXALL CORPORATION.

APPROVED BY: \_\_\_\_\_

DATE: \_\_\_\_\_

**RoHS COMPLIANT**

0A	JGK	11/21/19	DRAWING CREATED FOR PDR #18004.	
REV.	INIT.	DATE	DESCRIPTION	
			ALL INFORMATION ILLUSTRATED IS THE PROPERTY OF "CONXALL CORPORATION". UNAUTHORIZED DUPLICATION OR DISTRIBUTION OF THIS DOCUMENT IS PROHIBITED.	
			ORIG. DRAWN BY: JGK	DATE: 11/21/19
			601 E. WILDWOOD VILLA PARK, IL 60181	
			TITLE: CABLE TO CABLE CONN. ASS'Y (2-3) #20 PIN CONTACTS, SOLDER CUP INSTA-CLICK, MICRO-CON-X STANDARD PRODUCT	
			SCALE: NTS	SHEET: 1 OF 1
			FILE: W18282-XPG-P-5XX	DIRECTORY: SLW
			PART NUMBER: W18282-XPG-P-5XX	REV: 0A