

STEP 1
STRIP CABLE AS SHOWN.
FEED THE END OF THE CABLE THROUGH THE BOOT, CABLE CLAMP HOUSING, AND COUPLING RING IN THE ORDER AND POSITION SHOWN.
CRIMP CONDUCTOR TO CONTACT.
CONTACT #1 TO BE NEXT TO NOTCH.

**REMAINING CONTACTS TO BE PLACED COUNTER CLOCKWISE.

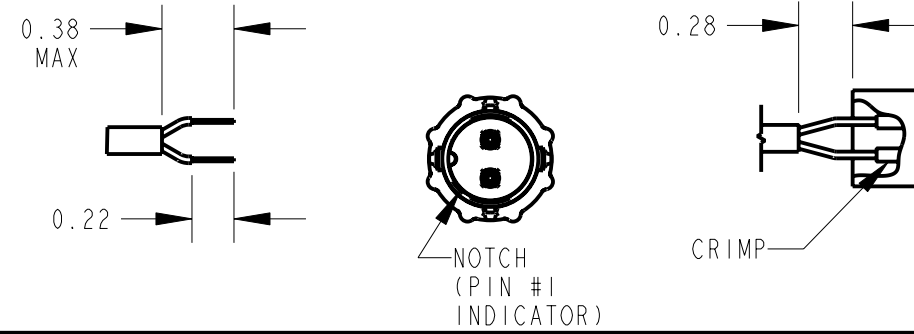

STEP 2
ALIGN COUPLING RING'S TABS WITH CORD CONNECTOR'S SIDE NOTCHES AND PUSH THE COUPLING RING ONTO CORD CONNECTOR.

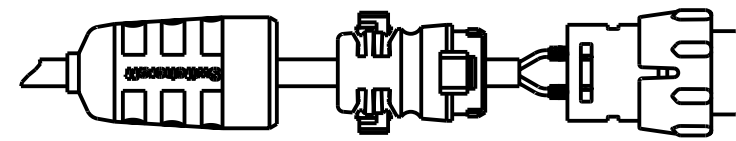

STEP 3
PUSH THE CABLE CLAMP HOUSING FORWARD UNTIL IT LOCKS INTO THE CONNECTOR BODY AND SNAP THE TWO CLAMPS INTO ITS COMPARTMENTS.

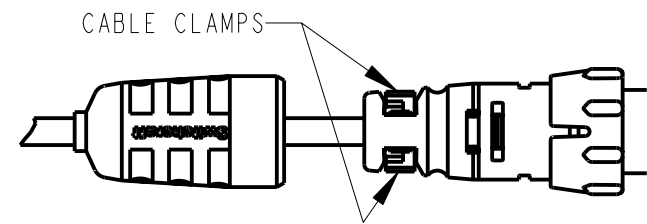

STEP 4
PUSH THE BOOT ALL THE WAY FORWARD TO SEAT TIGHTLY ONTO THE CABLE CLAMP HOUSING.

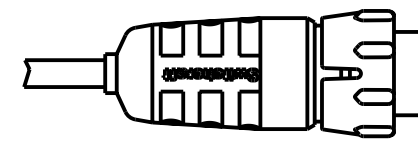

SPECIFICATIONS

MECHANICAL:
SHOCK: MIL-STD 202 METHOD 213B, COND. K.
VIBRATION: MIL-STD 202 METHOD 201
LIFE: 300 INSERTION/WITHDRAWAL CYCLES (MINIMUM)

ELECTRICAL
DIELECTRIC WITHSTANDING VOLTAGE: 1,000 VAC
INSULATION RESISTANCE: 100 MEGOHMS (MIN) AT 77°F
CONTACT RESISTANCE: 5.0 MILLOHMS MAX.
CURRENT RATING: 7.5 AMPS (#20 CONTACT)
13.0 AMPS (#16 CONTACT)

ENVIRONMENTAL
TEMPERATURE LIMITS: -40°C TO +65°C (NON-OPERATING)
MOISTURE RESISTANCE: MIL-STD 202 METHOD 106F
INSULATION RESISTANCE: MIL-STD 202 METHOD 302, COND. B
THERMAL SHOCK: MIL-STD 202 METHOD 107G
SALT SPRAY: MIL-STD 202 METHOD 101D, COND. B
WATER TIGHTNESS TEST: U.S. COAST GUARD CFR 46 PART 110.20

NOTE: #7 AND #8 PIN NOT AVAILABLE IN MALE CORD CONNECTOR.

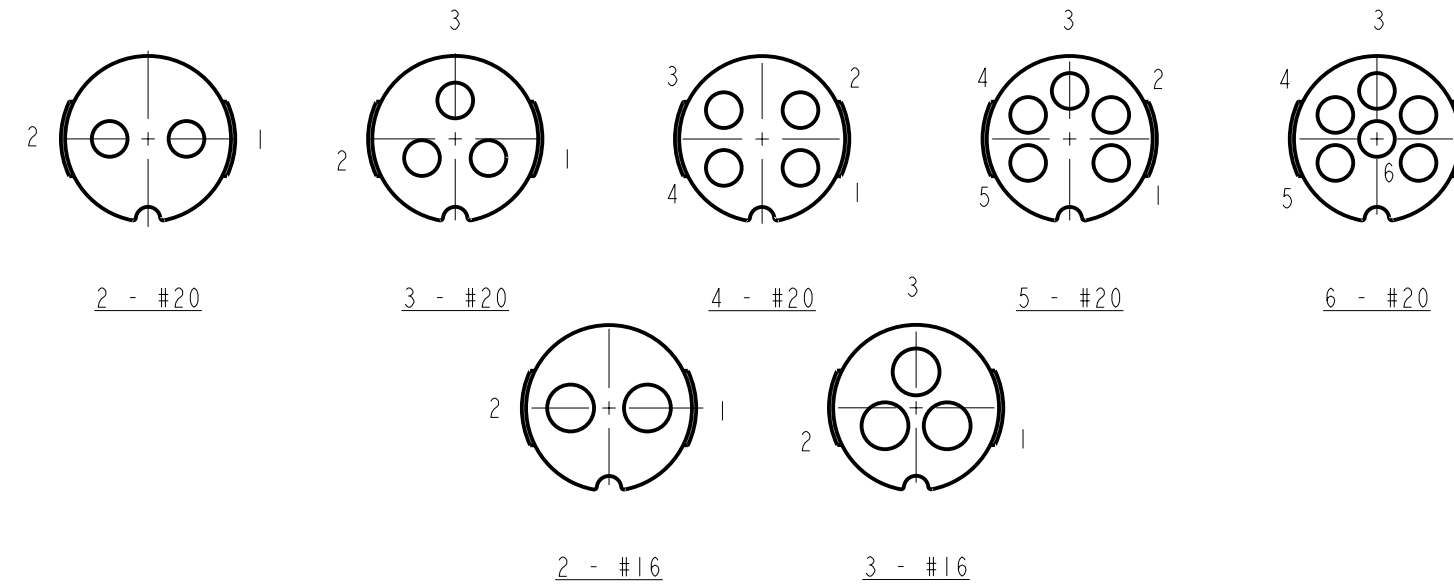

CONTACT ARRANGEMENTS

SHOWN ARE REAR VIEWS OF MALE CORD CONNECTORS

MATERIALS:
CORD CONNECTOR SHELL, CONTACT LOCKING DISK, COUPLING RING AND CABLE CLAMP ASSEMBLY:
THERMOPLASTIC POLYMER GLASS FIBER, FLAME RETARDANT
REAR BOOT AND CONNECTOR SHELL INTERIOR:
THERMOPLASTIC RUBBER
CONTACTS: COPPER BASE ALLOY GOLD-PLATED OVER NICKEL UNDERPLATE

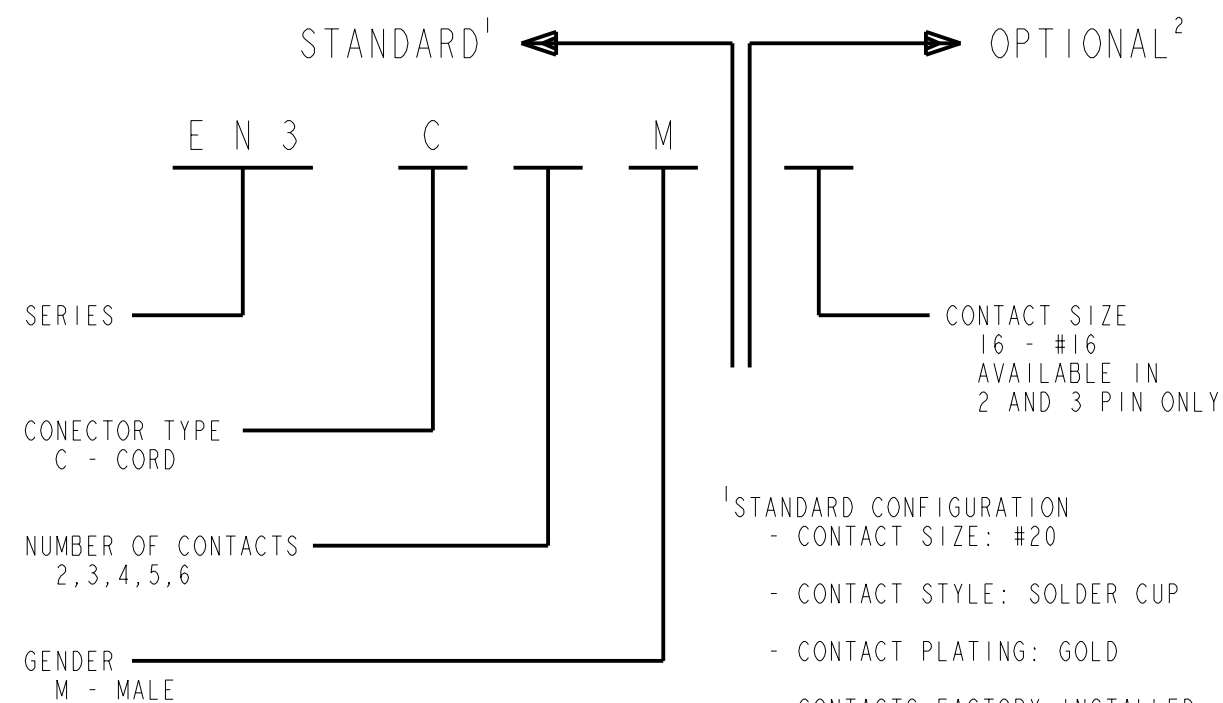
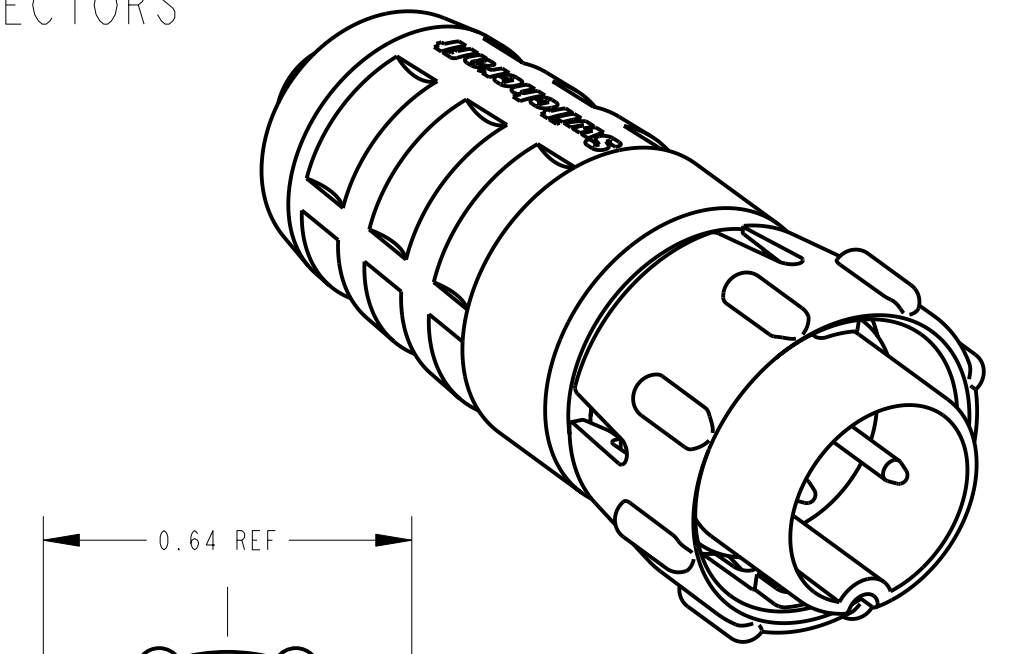
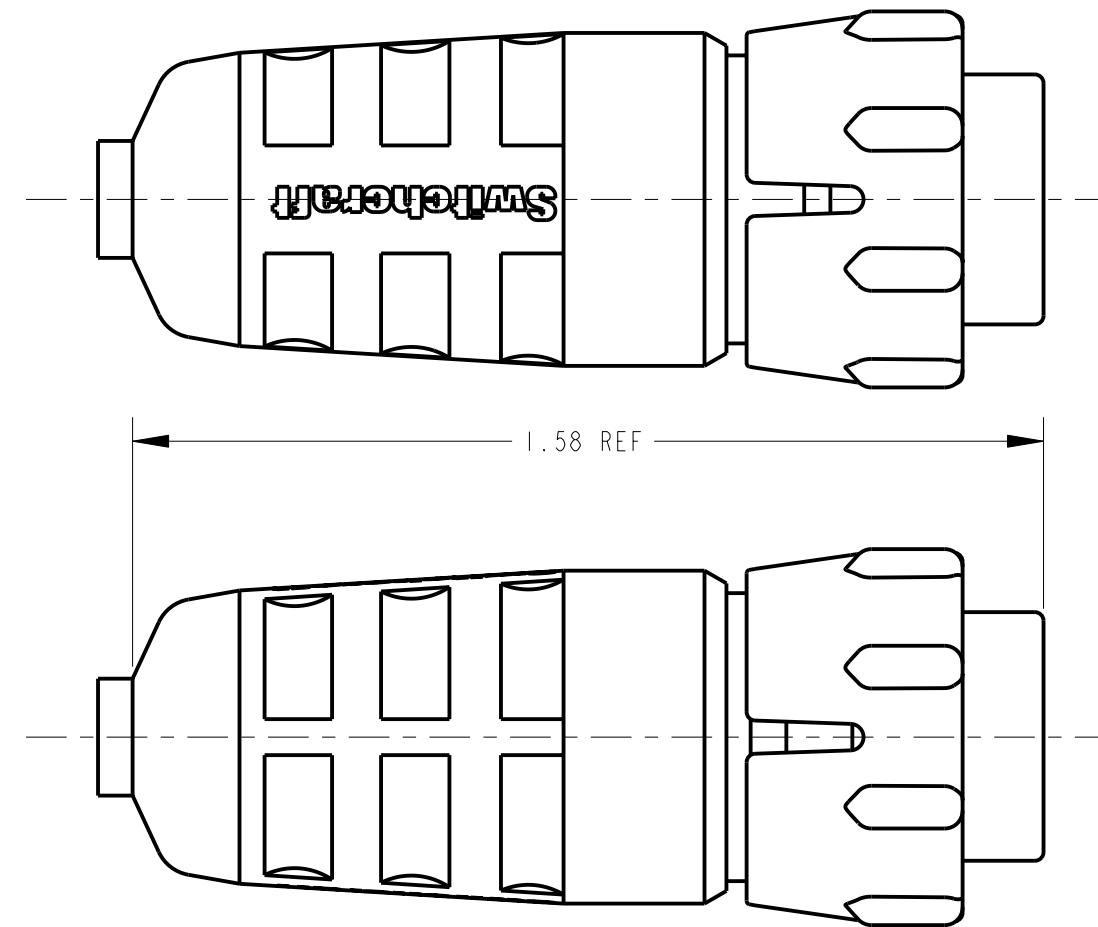

¹STANDARD CONFIGURATION
- CONTACT SIZE: #20
- CONTACT STYLE: SOLDER CUP
- CONTACT PLATING: GOLD
- CONTACTS FACTORY INSTALLED
- PACKAGED IN BULK

²OPTIONAL CONFIGURATION
- LEAVE BLANK FOR STANDARD CONFIGURATION

★ STAR SYMBOL DENOTES CRITICAL DIMENSION

UNLESS OTHERWISE SPECIFIED

- ALL DIMENSIONS IN INCHES
- TWO PLACE DECIMALS ±0.01
- THREE PLACE DECIMALS ±0.005
- ANGLES ±1°
- ALL DIA. CONCENTRIC WITHIN 0.005 T.I.R.
- FEATURES ON THE SAME CENTERLINE MUST BE ALIGNED WITHIN ±0.002
- REMOVE ALL BURRS

DO NOT SCALE DRAWING

THIS DRAWING DESCRIBES A DESIGN CONSIDERED PROPRIETARY IN NATURE, DEVELOPED AND MANUFACTURED BY SWITCHCRAFT INC. AND IS RELEASED ON A CONFIDENTIAL BASIS FOR IDENTIFICATION PURPOSES ONLY.

SIZE	WIDTH	MULT	LBS/M	TEMPER
FINISH				
SPEC No.		MATERIAL SPEC No.		
FIRST USED ON		SCALE 3:1		
DATE DRAWN	BY	CHKD	APVD	
11-28-95	SG	11-28-95	RB	
NAME				REV
MALE CORD CONNECTOR				G
PART No.			EN3C_M	

CUSTOMER DRAWING