

DIMENSIONS ARE FOR REFERENCE ONLY

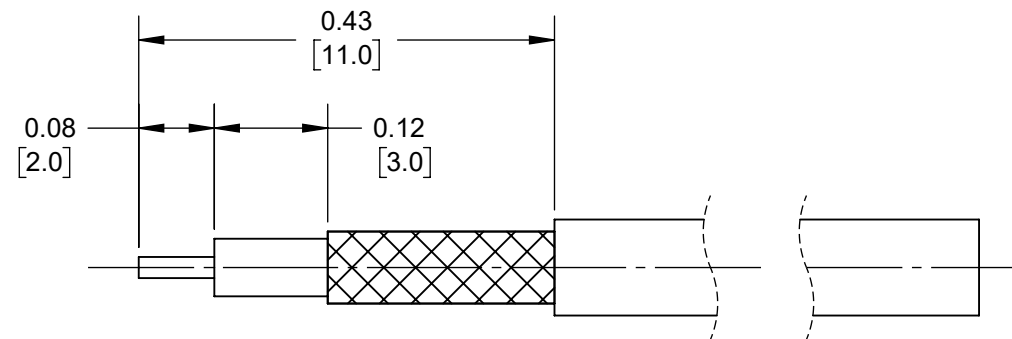

RECOMMENDED RG-316/U CABLE STRIP DIMENSIONS
(CUSTOMER SUPPLIED CABLE)

NOTES:

- PARTS ARE SUPPLIED UNASSEMBLED.
- MATERIAL:
BODY, PIN: BRASS (C3604), GOLD PLATED
SLEEVE: COPPER (C1220), NICKEL PLATED
INSULATOR: TEFLON, WHITE
SPRING WASHER: STAINLESS STEEL (SUS)
O-RING: SILICONE, RED
- WIRING INSTRUCTIONS:
INSERT CABLE THROUGH CRIMP SLEEVE,
STRIP ONE END OF CABLE,
SOLDER CONDUCTOR TO CONTACT PIN,
PUSH PIN AND CABLE INTO CONNECTOR HOUSING,
PULL CRIMP SLEEVE OVER BRAID TO REAR OF CONNECTOR,
CRIMP SLEEVE WITH 0.132 (3.35mm) HEX
- THESE PARTS ARE RoHS COMPLIANT.

CUSTOMER DRAWING

					THIS DRAWING DESCRIBES A DESIGN CONSIDERED PROPRIETARY IN NATURE, DEVELOPED AND MANUFACTURED BY SWITCHCRAFT INC. AND IS RELEASED ON A CONFIDENTIAL BASIS FOR IDENTIFICATION PURPOSES ONLY.				
					SIZE	WIDTH	MULT	LBS/M	TEMPER
					FINISH			MATERIAL	
					SPEC No.			SPEC No.	
					FIRST USED ON		SCALE 2:1		
					DATE DRAWN	BY	CHKD	APVD	
					3-7-2024	SRC	SRC	SRC	
							3-7-2024	3-7-2024	
					NAME			PART No.	
					SMA PIN PLUG			SMAPRG316	
					FOR RG316 CABLE			REV A	
REVISIONS					DO NOT SCALE DRAWING				
A	28773	10-23-25	PC	TJK					
REV	ECO NUMBER	DATE	BY	APVD					