

# Shielded MULTI-CON-X<sup>®</sup> Assembly Instructions

## SHIELDED MULTI-CON-X<sup>®</sup> CABLE END ASSEMBLY (CRIMP):

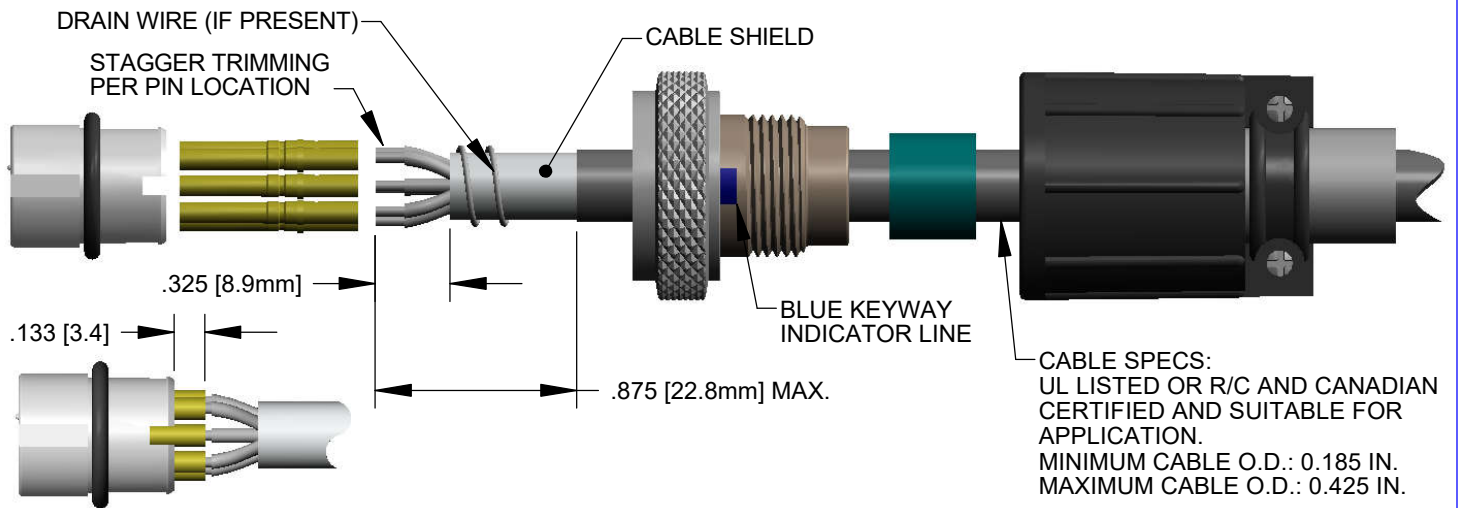
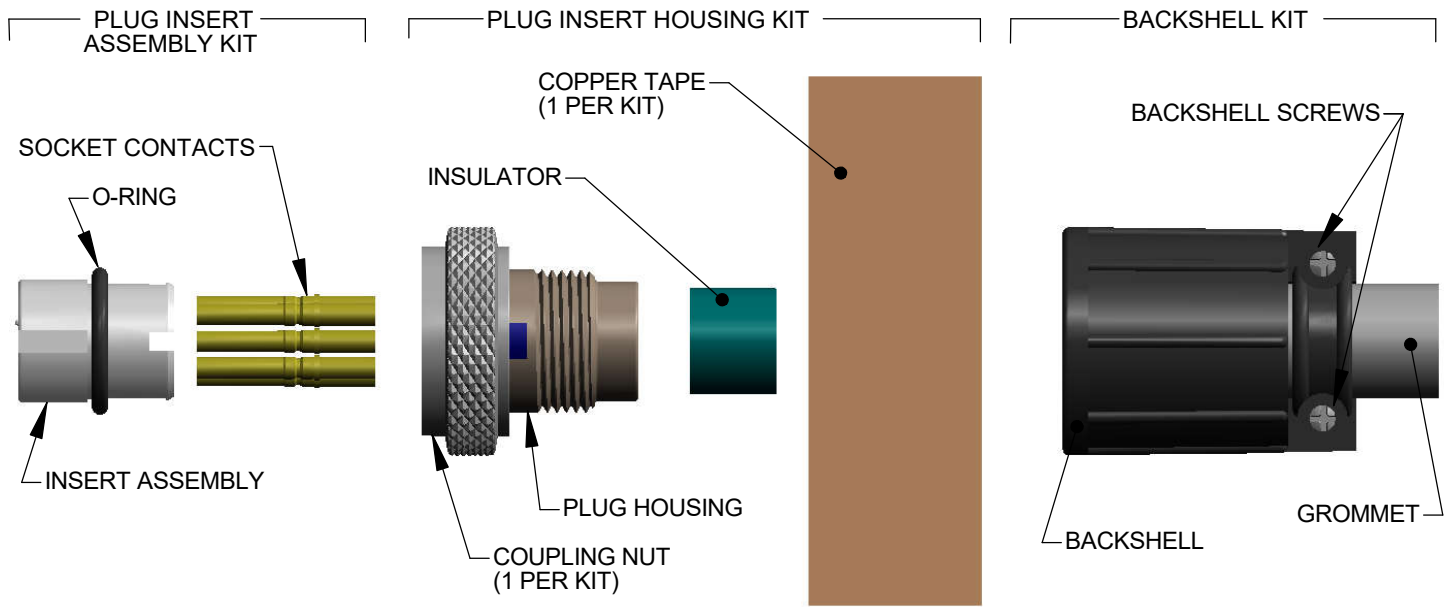

**STEP 1:** SLIDE BACKSHELL, PLUG HOUSING, AND INSULATOR ONTO CABLE IN THE ORDER SHOWN.

**STEP 2:** STRIP CABLE JACKET AND WIRES TO LENGTH. EXCESS CABLE SHIELD MUST BE TRIMMED OR WRAPPED AROUND WIRES. IF PRESENT, USE THE DRAIN WIRE TO WRAP THE CABLE SHIELD IN PLACE.

**STEP 3:** CRIMP WIRES INTO CONTACTS ACCORDING TO YOUR SPECIFICATIONS AND PER PIN ARRANGEMENTS BELOW.  
**STEP 3A:** INSERT THE WIRED CONTACT INTO THE CAVITY AND FIRMLY PUSH THE CONTACT UNTIL IT LOCKS INTO PLACE. GIVE A SLIGHT PULL ON THE WIRE TO INSURE THE CONTACT IS SEATED. THE CONTACT BARREL SHOULD PROJECT BEYOND THE INSERT BY APPROXIMATELY 0.133 [3.4]

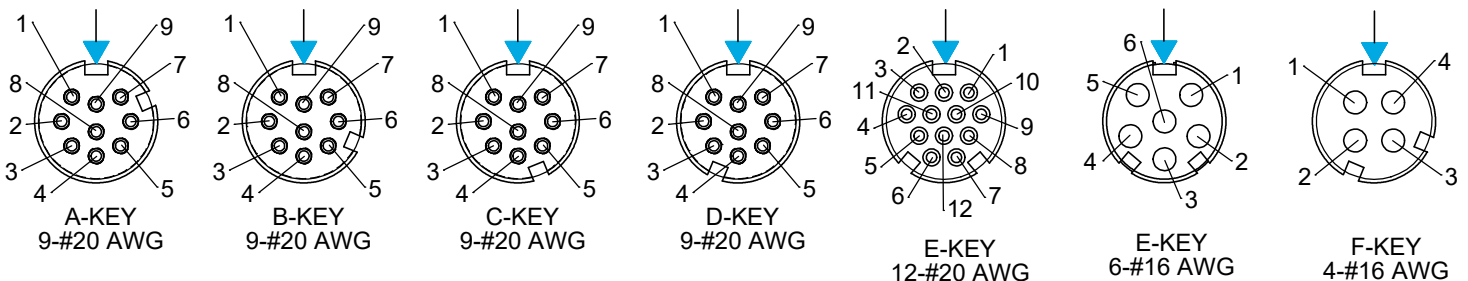

NOTE: CONTACT ARRANGEMENTS SHOWN ARE WIRING VIEW OF CABLE END SOCKET (PIN INSERT OPPOSITE)

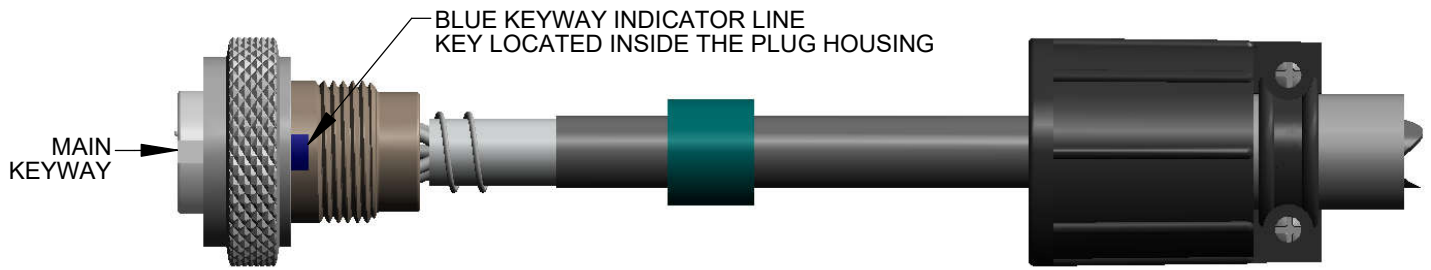

**STEP 4:** ALIGN MAIN KEYWAY OF PLUG INSERT WITH THE BLUE KEYWAY INDICATOR LINE AND PRESS PLUG INSERT INTO PLUG HOUSING UNTIL IT SNAPS IN PLACE. MAKE CERTAIN THAT THE O-RING (LOCATED ON THE PLUG INSERT ASSEMBLY) IS IN PLACE.

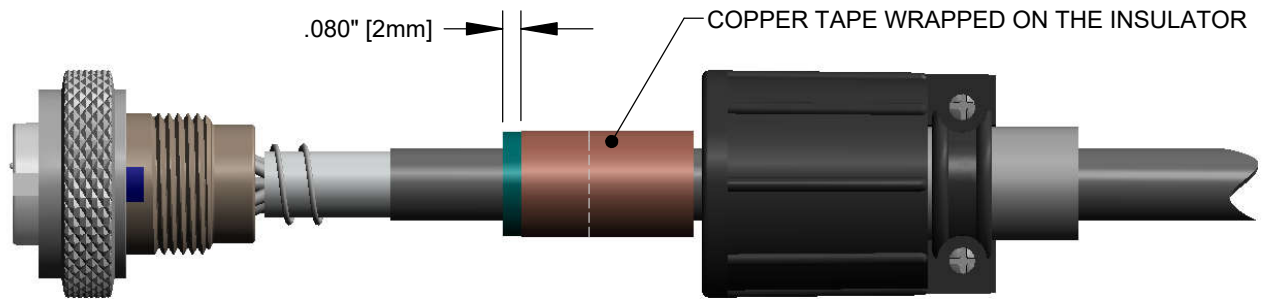

**STEP 5:** PEEL-OFF THE BACKING OF ONE PIECE OF COPPER TAPE, WRAP THE TAPE AROUND THE INSULATOR AS SHOWN.



**STEP 6:** SLIDE INSULATOR WITH THE COPPER TAPE INTO THE BACK OF THE PLUG HOUSING. FORM FREE END OF COPPER TAPE TIGHTLY ONTO THE SHIELD OF THE CABLE. MAKE CERTAIN NEITHER THE COPPER TAPE NOR THE CABLE SHIELDING TOUCH ANY OF THE TERMINALS.

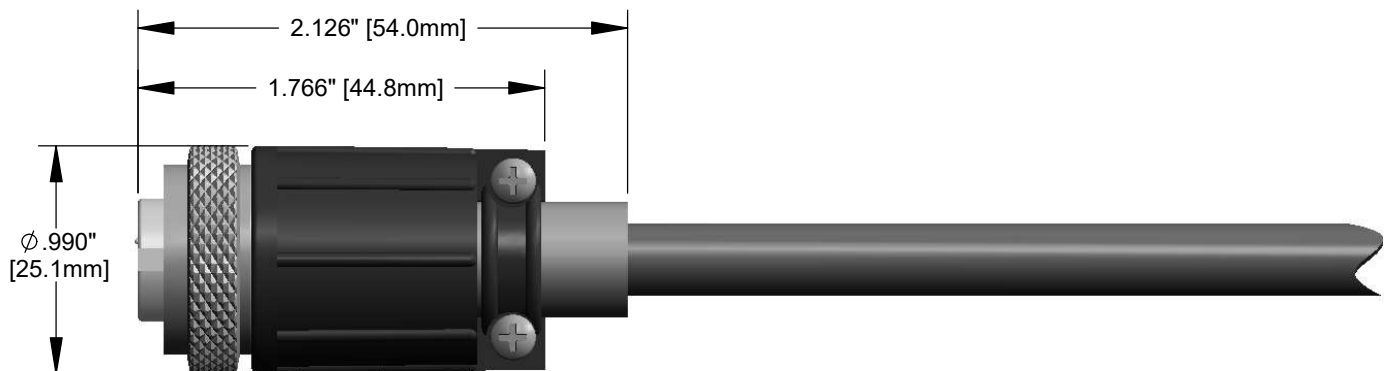

**STEP 7:** SLIDE THE BACKSHELL ASSEMBLY UP AGAINST THE PLUG INSERT ASSEMBLY. HOLD THE PLUG INSERT HOUSING AND THREAD THE BACKSHELL ONTO IT. TIGHTEN FIRMLY BY APPLYING 4 - 5 LB-IN [0.45 - 0.56 N-m] TIGHTENING TORQUE.

**STEP 8:** TIGHTEN THE TWO BACKSHELL SCREWS TO SECURE THE CABLE IN THE BACKSHELL.