

INSTRUCTION SHEET

MULTI-CON-X #14 SCREW TERMINAL CONTACT SERIES CABLE CONNECTOR ASS'Y

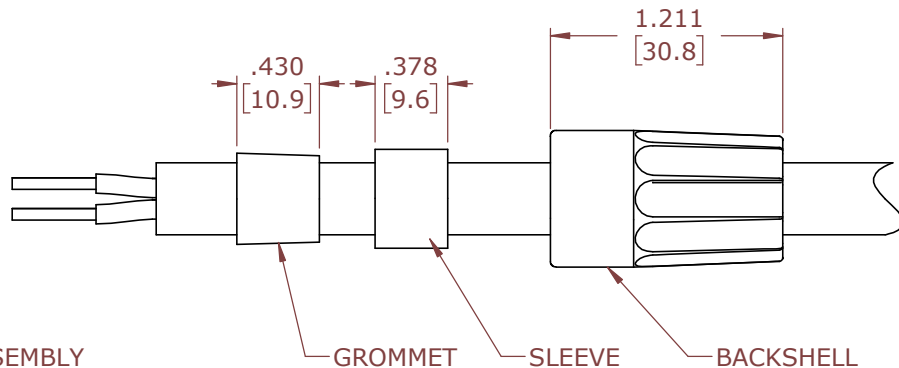

USE 0.035" ALLEN WRENCH

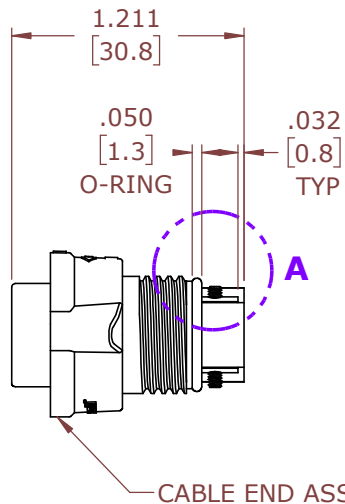
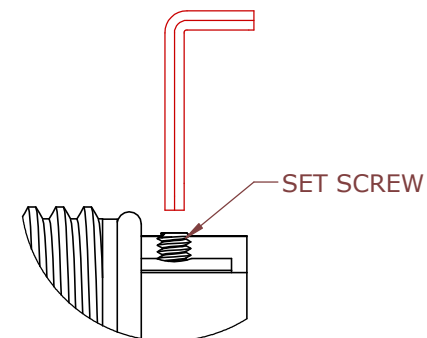

DETAIL A

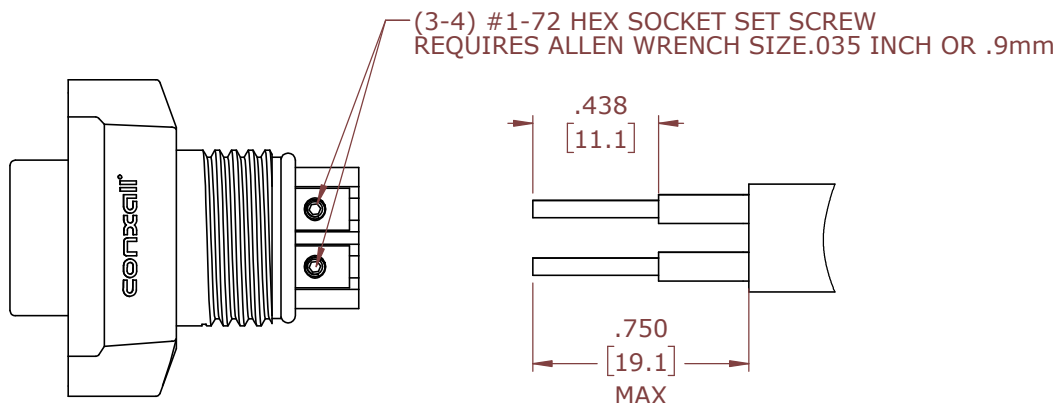

RECOMMENDED STRIPPING LENGTH

NOTES:

1. COUPLING RING, O-RINGS, CONTACTS AND SET SCREWS SHIPPED ASSEMBLED
2. CONTACTS ACCEPT 12, 14, AND 16 AWG WIRES
3. SET SCREW NEED TO BE BACKED OUT WITH ALLEN WRENCH PRIOR TO INSERTING WIRE CONDUCTORS
4. STRIP CABLE JACKET 3/4" MAX. STRIP WIRE INSULATION ABOUT 7/16"
5. INSERT STRIPPED CONDUCTOR INTO THE CONTACT OPENING, SET SCREW SHOULD BE TIGHTENED WITH THE ALLEN WRENCH AS NEEDED TO RETAIN CONDUCTOR
6. ALL DIMENSIONS ARE REFERENCE

DIMENSIONS IN BRACKETS [] ARE IN MILLIMETERS UNLESS INDICATED

RoHS COMPLIANT

A	CS	10-02-24	DRAWING CREATED PER DOR 24-E284PK
REV.	INIT.	DATE	DESCRIPTION
CHECKED BY:			PART NUMBER: LAB - 0052
APPROVED BY:			 601 E. WILDWOOD VILLA PARK, IL 60181
FILE:	SIZE: A	SHEET 1 OF 1	